

LTM Series

MPPT Solar Charge Controller

User Manual



Model: LTM4830 | LTM4840

Battery Voltage Support: 12V/24V/36V/48V

Max PV Voltage: 120V

Max Charging Current: 30A/40A

Max Load Current: 30A

Table of Contents

1	About This Manual	2
1.1	Purpose	2
1.2	Scope	2
2	Safety Instructions	2
3	Product Introduction	3
3.1	Overview	3
3.2	Features	3
3.3	Product Appearance	5
3.3.1	Diagram	5
3.4	LED Indicators	6
3.5	Battery Parameters	6
3.6	Load Mode	7
3.7	RS485 Interface	7
3.8	Specifications	8
4	Technical Features	8
4.1	MPPT Technology	8
4.2	Digital Control Technology	8
4.3	Multiple Protection Functions	9
4.4	Three-Stage Charging Mode	9
4.5	Bluetooth/WiFi Communication	9
4.6	Flexible Load Control	10
5	Product Installation	10
5.1	Installation Dimensions	10
5.2	Installation Environment	10
5.3	Installation Steps	11
5.4	Wiring Specifications	11
6	Protection Functions and System Maintenance	12
6.1	Protection Functions	12
6.2	System Maintenance	12
7	APP Introduction	13
7.1	APP Download	13
7.2	User Registration and Login	13
7.3	Adding Devices	14
7.4	Device IoT Services	15
7.5	Device Status	17

7.6	Battery Parameter Settings	18
7.6.1	Lead-Acid Batteries	19
7.6.2	Lithium Batteries	20
7.7	Load Parameter Settings	21
7.8	Time Setting	21
7.9	Bluetooth Settings	23
7.10	Device Information and Firmware Upgrade	24

1 About This Manual



1.1 Purpose

Thank you for choosing the LTM Series MPPT Solar Charge Controller. This manual describes the assembly, installation, operation, and troubleshooting methods of this device. Please read this manual carefully before installation and operation. Keep this manual properly for future reference.

1.2 Scope

This manual provides product introduction, usage methods, safety and installation guidelines, as well as information about the accompanying Noi Solar APP.

2 Safety Instructions

Symbol	Description
 Warning	Indicates a dangerous operation; safety preparations must be completed before proceeding.
 Attention	Indicates an operation that may cause damage.
 Tip	Suggestions and tips for the operator.

1. Since this controller operates above human safety voltage levels, please read the instruction manual thoroughly and complete safety training before operating the controller.
2. Do not disassemble or repair the controller yourself. If maintenance or repair is needed, please send it to a professional center to prevent electric shock or fire risks.
3. The controller is not waterproof. Install and use the controller indoors.
4. Install the controller in a well-ventilated location. The heat sink temperature may be very high during operation.
5. Select appropriate cable size according to maximum current to ensure optimal operation of the charging controller.
6. When installing or disconnecting wiring, carefully follow the installation procedures as described in the installation section of this manual.
7. Connect wiring strictly according to positive and negative polarity indicators. Never reverse polarity or create short circuits.

3 Product Introduction

3.1 Overview

This product can detect solar panel power generation in real-time and track its maximum power point, enabling it to charge batteries with maximum output power. This product is used in off-grid solar systems, coordinating the work of solar panels, batteries, and loads. It is the core control component of off-grid photovoltaic systems.

This product uses LED lights to display operational status. It can be monitored via smartphone APP/PC software through Bluetooth, WiFi, or RS485 to view detailed operational status, logs, and control parameters. Users can modify various control parameters according to their needs to adapt to different application requirements.

The controller uses standard Modbus communication protocol and can easily achieve remote monitoring through smartphone APP. The controller has built-in comprehensive fault self-diagnosis and electronic protection functions such as overvoltage and overcurrent protection, which can maximize protection against product damage caused by various reasons.

3.2 Features

- The controller uses dynamic conductance incremental method to monitor solar panel power changes in real-time, dynamically tracking the maximum power point of the solar panel with variable step increments. This increases charging power and efficiency while providing stable DC voltage with low ripple to the battery end, significantly extending battery life.
- MPPT tracking efficiency can reach up to 99%.
- Advanced digital power synchronous buck circuit technology with energy conversion efficiency up to 98%.
- Built-in solar panel maximum power algorithm, which is approximately 20% more efficient than traditional PWM controllers.
- Controller supports automatic activation of lithium batteries by solar panels and enables 0V battery startup.
- Battery support for 12V/24V/36V/48V auto-identification, compatible with lead-acid and lithium battery charging.
- Provides USB 5V/2A charging interface.
- Supports high-current inductive and capacitive load starting.
- Supports fault LED indication. Users can connect smartphone APP to view detailed fault logs and diagnostic functions. The controller also supports wireless Bluetooth&WiFi

connection with smartphone APP, allowing local or remote configuration of battery types and load mode parameters as well as real-time monitoring of equipment operation status.

- Controller has built-in charging and discharging current limiting functions. Users can set maximum charging and discharging currents via smartphone APP.
- Comprehensive protection functions: overvoltage and overcurrent protection for charging; overheating protection; short-circuit and overcurrent protection for loads; low-voltage and overvoltage protection for batteries; anti-reverse connection and lightning protection for solar panels.
- Provides one group of RS485 bus using standard Modbus protocol to meet user requirements in different situations.

3.3 Product Appearance

The controller housing is made of flame-retardant material, and the heat sink is aluminum alloy material with good heat dissipation performance and mechanical strength. The front panel of the controller has LED indicator lights to show working status and fault information. Mounting holes are located on both sides of the protruding structure, facilitating installation and fixation.

3.3.1 Diagram

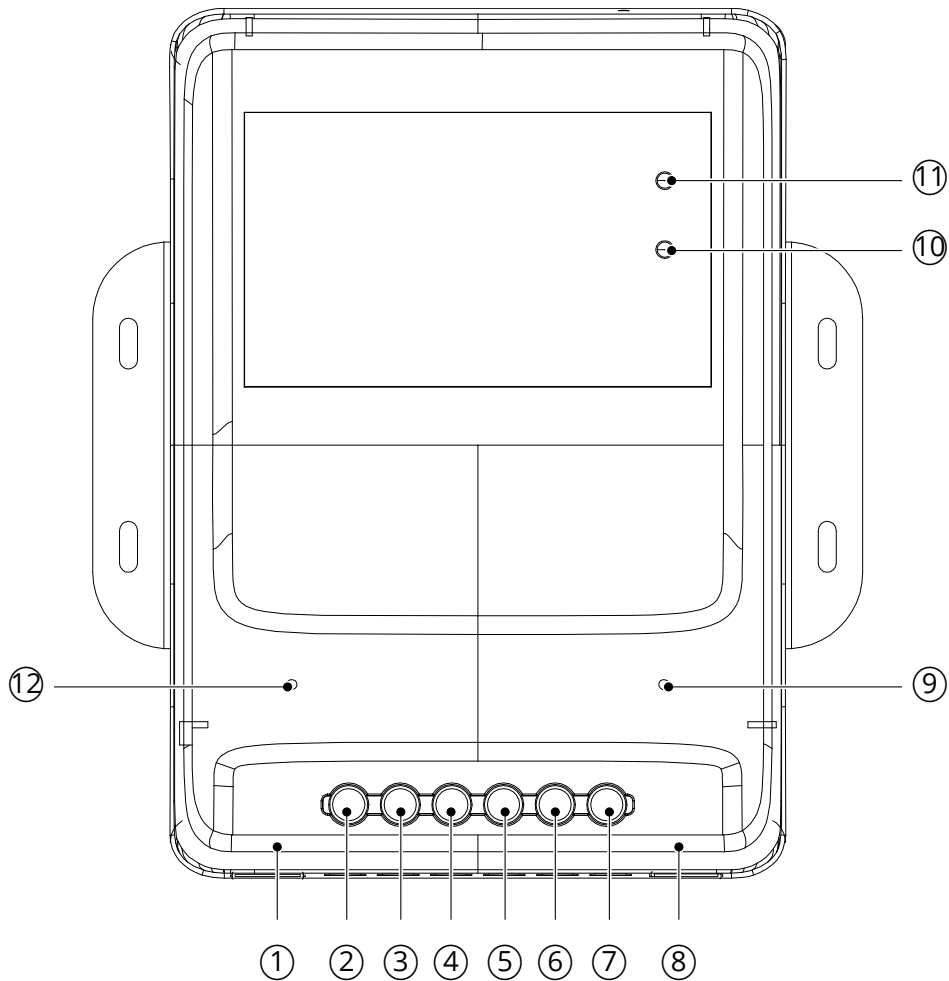

- | | |
|-------------------|---------------------------|
| ① RS485 Interface | ⑦ Load - |
| ② Solar Panel + | ⑧ USB Ports |
| ③ Solar Panel - | ⑨ Load Indicator |
| ④ Battery + | ⑩ Battery Indicator |
| ⑤ Battery - | ⑪ Communication Indicator |
| ⑥ Load + | ⑫ Charging Indicator |

3.4 LED Indicators

Bluetooth WiFi (Blue)	Slow Blink	Not Connected	Battery (Yellow)	Steady On	Battery Normal
	Steady On	Connected		Slow Blink	Low Battery
	Fast Blink	Communicating		Fast Blink	Overvoltage
Load (Red)	Off	Load Off	Charging (Green)	Off	Charging Off
	Steady On	Load On		Fast Blink	Fast Charging
	Slow Blink	Load Overcurrent		Steady On	Absorption Charging
	Fast Blink	Load Short Circuit		Slow Blink	Float Charging

3.5 Battery Parameters

Battery Type	Sealed	Gel	Flooded	LiFePO4	Lithium	Custom
	SLD/AGM	GEL	FLD	LiFePO4	Li	User
Battery Voltage	12V	12V	12V	12V(4 cells)	12V(3 cells)	12V
Equalization Voltage	0V	0V	14.8V	0V	0V	14.6V
Equalization Interval	0	0	30 days	0	0	0
Equalization Duration	0	0	120 minutes	0	0	0
Bulk Voltage	14.4V	14.2V	14.6V	14.2V	12.6V	14.4V
Bulk Resume Voltage	13.0V	13.0V	13.0V	14.0V	12.3V	13.0V
Float Voltage	13.7V	13.7V	13.7V	-	-	13.7V
Low Disconnect Voltage	11.2V	11.2V	11.2V	11.2V	10.8V	11.2V
Low Resume Voltage	12.6V	12.6V	12.6V	12.6V	11.4V	12.6V

*The table above uses 12V battery as example. For 24V/36V/48V batteries, multiply the corresponding parameters by 2/3/4 respectively.

*LiFePO4 and Lithium batteries can have charging parameters set according to the number of series, and they have different configuration types. the above table is for reference only.

⚠Attention For custom parameters, please fill in the values strictly according to the battery manual. Incorrect parameters may cause battery damage.

⚠Warning LiFePO4 and Lithium batteries must have protection boards, otherwise there is risk of fire or explosion.

3.6 Load Mode

Mode	Description
Always On	Load always on
Manual	Manually switch load via APP
Battery Voltage	Switch load based on battery voltage Example: Open load when battery voltage $\geq 13V$ Close load when battery voltage $< 12V$
Light	Switch load based on light (day/night) Example: Open load when solar panel voltage $\leq 4V$ Close load when solar panel voltage $> 5V$
Light Timer	Light control mode with load duration time
Light Repeat	Light control mode with repeat control
Repeat	Load turns on and off in cycles
Segments	Switch load based on set time periods

💡 Tip Light control mode has **output reverse** function, which can achieve opening load during daytime and closing at night.

⚠️ **Attention** During low battery protection, the load will be forced to close.

3.7 RS485 Interface

The RS485 interface uses an RJ45 connector. This interface can connect to other devices such as data acquisition modules, gateway modules, etc. The default baud rate is 115200, which can be adjusted via the APP.

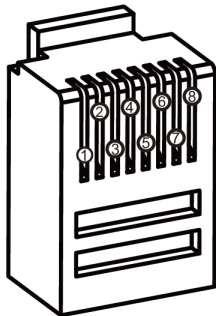

Figure 1: RS485 Interface

No.	Definition	No.	Definition
①	NC	⑤	Positive Power
②	Ground	⑥	Ground
③	NC	⑦	D+
④	Positive Power	⑧	D-

3.8 Specifications

Model	LTM4830	LTM4840
System Voltage	12V/24V/36V/48V	
No-load Loss	0.7W~1.2W	
Battery Voltage	10V~57.6V	
Max PV Voltage	120V	
Max Charging Current	30A	40A
Max Load Current	30A	
Max PV Power	390W/12V	520W/12V
	780W/24V	1040W/24V
	1100W/36V	1440W/36V
	1440W/48V	1920W/48V
Conversion Efficiency	92%~99%	
MPPT Tracking Efficiency	≥99%	
USB Interface	5V2A	
Wireless Communication	Bluetooth BLE5.0/WiFi 2.4G	
RS485 Communication	RS485 Interface, Default Baud Rate 115200	
Wire Terminals	Maximum 6AWG/13mm ²	
Operating Temperature	-25°C~+50°C	
Shell Material	Flame-retardant ABS, Aluminum alloy heat sink	
Weight	750g	800g
Dimensions	171×121×59mm	

4 Technical Features

4.1 MPPT Technology

Maximum Power Point Tracking (MPPT) technology adjusts the working voltage of solar panels to keep them operating at the maximum power point under different lighting conditions, thereby improving the overall efficiency of the photovoltaic system. The LTM Series MPPT Controller uses advanced MPPT algorithms that can respond quickly to light changes and achieve efficient charging.

4.2 Digital Control Technology

The LTM Series MPPT Controller uses digital control technology, monitoring and adjusting charging parameters in real-time through high-speed microprocessors to improve system stability and reliability. At the same time, digital control technology gives the controller

stronger function expansion capabilities, supporting multiple communication interfaces and remote monitoring functions.

4.3 Multiple Protection Functions

The LTM Series MPPT Controller has built-in multiple protection functions including over-voltage protection, overcurrent protection, short-circuit protection, reverse connection protection, and overheating protection to ensure safe operation of the system in various abnormal situations and extend equipment service life.

4.4 Three-Stage Charging Mode

The LTM Series MPPT Controller uses a three-stage charging mode for lead-acid batteries, including fast (Bulk) charging, absorption (Abs) charging, and float (Float) charging, effectively protecting the battery and extending its service life. By intelligently adjusting charging parameters, it ensures the battery receives optimal charging effect in different states.

Fast Charging (Bulk): When the battery voltage is low, the controller performs rapid charging with maximum charging current to quickly increase the battery voltage.

Absorption Charging (Abs): When the battery voltage reaches the maximum charging voltage, it switches to constant voltage charging, allowing the battery to store more energy. This stage is also called the absorption stage.

Float Charging (Float): After absorption charging ends, it enters the float stage. In this stage, the charging voltage is reduced and small current charging is used to keep the battery fully charged. Float charging can prevent natural discharge of the battery while avoiding overcharging damage.

Equalization Charging

Equalization charging is used for maintenance of lead-acid batteries, generally applied to flooded (open) lead-acid batteries to balance battery voltage, decompose sulfate deposits, and prevent electrolyte stratification. This maintenance procedure ensures all batteries reach uniform charging state, enhancing battery performance, restoring capacity, and extending battery life. Equalization charging time should not be too long (default 120 minutes) nor too frequent (default interval 30 days).

4.5 Bluetooth/WiFi Communication

The LTM Series MPPT Controller supports simultaneous Bluetooth and WiFi communication, allowing local and remote access at the same time. Local Bluetooth is stable and efficient, especially simple and practical in network configuration and environments without WiFi. WiFi is used to achieve IoT remote access. Supporting both local and remote access provides complementary advantages, making users more convenient to view system status,

adjust parameters, and obtain fault information, improving system operability and convenience.

4.6 Flexible Load Control

The LTM Series MPPT Controller supports multiple load control modes including Always On, Manual, Light Control, Light Timer, Loop, Segments, etc. Users can select suitable load control modes according to their needs to achieve flexible load control.

5 Product Installation

5.1 Installation Dimensions

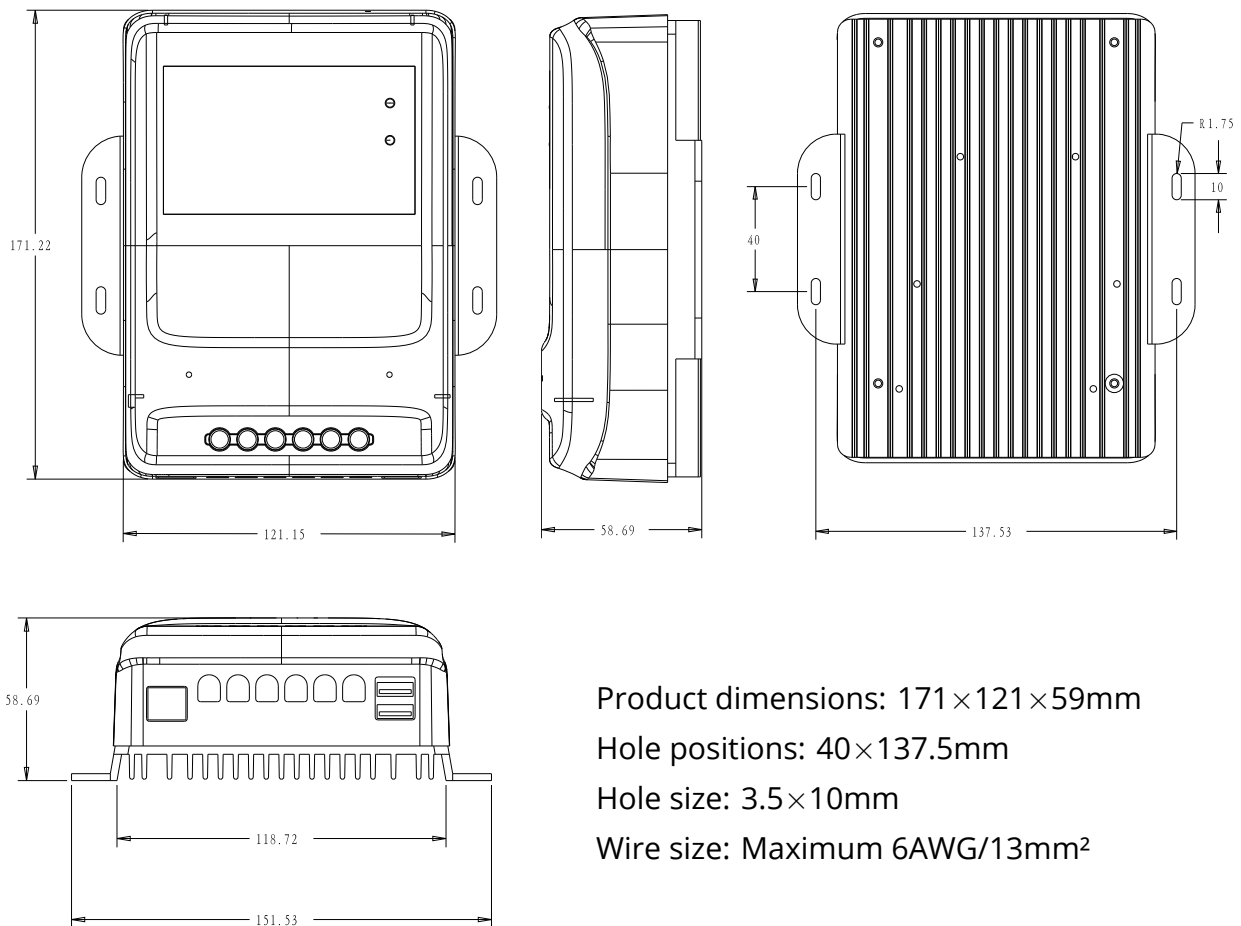

5.2 Installation Environment

- Installation location should have good ventilation, avoiding direct sunlight and rain.
- Installation location should be away from flammable and explosive materials.
- Installation location should avoid dust and corrosive gases.

- Installation location should allow for heat dissipation, ensuring the controller heat sink has sufficient space for heat dissipation.

5.3 Installation Steps

⚠Warning Solar arrays may produce high open-circuit voltages. Disconnect circuit breakers or fuses before wiring.

1. Choose a suitable installation position to ensure the controller is securely mounted.
2. Use screws to fix the controller to the wall or bracket.
3. Connect the battery, load, and solar panel according to the wiring diagram, ensuring connections are correct and secure.

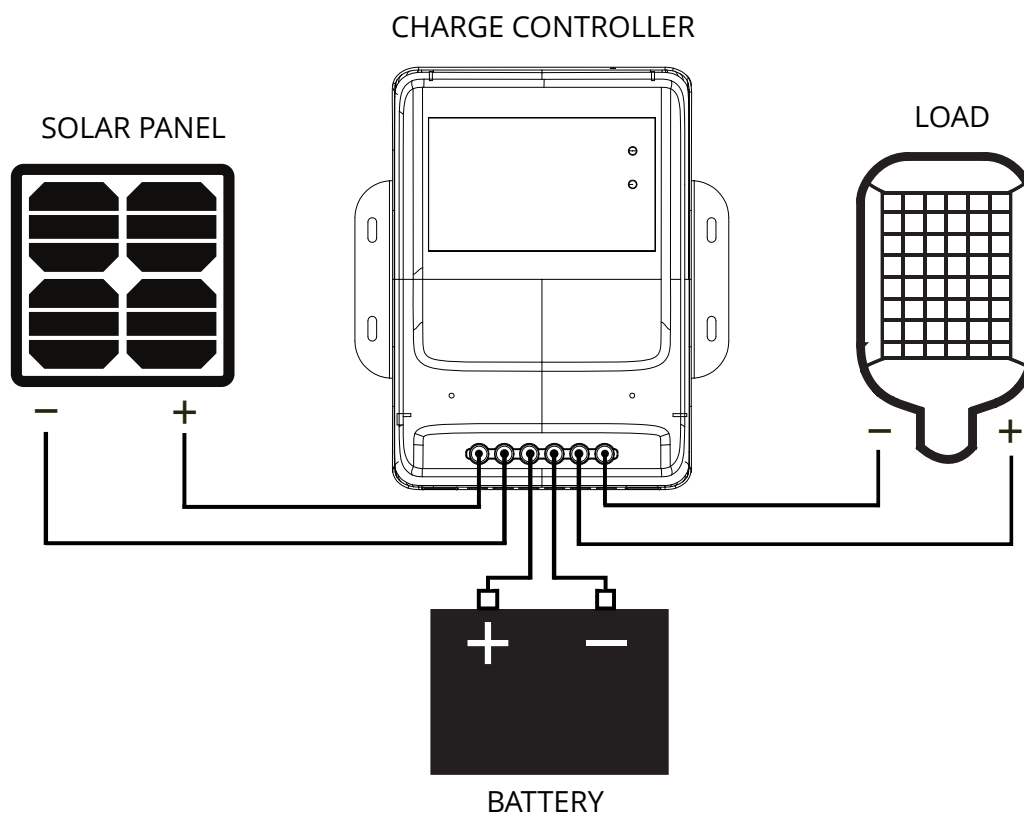

Figure 2: Connection Diagram

💡 Tip Connect battery first, then load, and finally solar panel.

⚠Warning Be careful when wiring to avoid polarity reversal or short circuits.

4. Check all connections are secure to ensure no loose connections or poor contact.
5. Power test to check if the controller operation status is normal.

5.4 Wiring Specifications

Wiring and installation methods must comply with national and local electrical regulations. Copper cables are recommended. For 30A current, minimum 8AWG/8mm² cable

should be used. For 40A current, minimum 7AWG/10mm² cable should be used. This controller can accept up to 6AWG/13mm² cables.

⚠Warning Too thin cables can cause overheating and fire risk.

6 Protection Functions and System Maintenance

6.1 Protection Functions

- **PV Protection**

Reverse connection protection, overvoltage protection, overcurrent protection, lightning protection, anti-backflow function.

- **Battery Protection**

Reverse connection protection, short circuit protection, overvoltage protection, under-voltage protection.

⚠Warning Reversing the battery terminal polarity will not damage the controller, but it will blow the fuse.

- **Load Protection**

Short circuit protection, overvoltage protection, overcurrent protection.

- **Overheat Protection**

When the controller detects high temperature, it will reduce charging current. If the temperature continues to rise, it will shut down charging and load output.

6.2 System Maintenance

- Regularly check if the controller's terminal connections are secure to prevent heating due to poor contact.
- Regularly check if there is dust accumulation on the controller heat sink, keep the heat sink clean to ensure good heat dissipation.
- Regularly check the controller's operating status to ensure all parameters are normal.
- If the controller is not used for a long time, disconnect the solar panel and battery connections to prevent battery over-discharge damage.

7 APP Introduction

This controller uses the Noi Solar APP for local and remote monitoring and parameter settings. The Noi Solar APP supports Android and iOS systems, allowing comprehensive setup and management of this controller including status viewing, parameter setting, data statistics, firmware upgrades, and other functions.

7.1 APP Download

There are two ways to get the APP: 1. Search for and download **Noi Solar** on the Apple App Store or Google Play. 2. Scan QR code to download APP.



Figure 3: Noi Solar



Figure 4: Apple App Store



Figure 5: Google Play

7.2 User Registration and Login

Open the APP (Figure 6), select "Login" in the Remote tab or "Login" in the top-left menu bar to enter the login interface (Figure 7). Click the "Register »" button in the upper right corner to enter the user registration interface (Figure 8). You can choose to register using email or phone number. After registration and login, you can see the logged-in user information in the user center of the top-left menu bar.

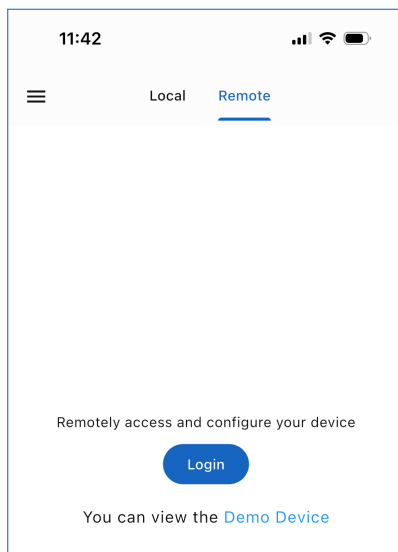

Figure 6: Open APP

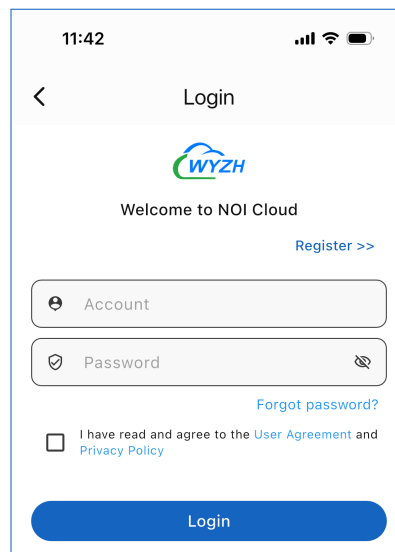

Figure 7: Login

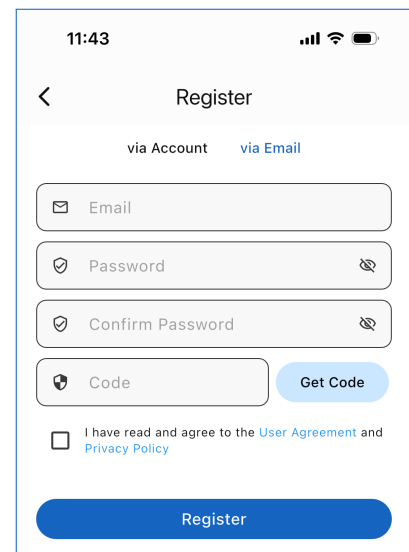

Figure 8: Email Registration

7.3 Adding Devices

Enter the APP and go to the Local tab (Figure 9). Click the "+" sign in the upper right corner of the title bar or the "Add Device" button in the middle of the interface to enter the search Bluetooth device interface (Figure 10).

Note: Please make sure Bluetooth functionality on your phone is enabled. When running the APP for the first time, click the "Add Device" button. A permission request dialog box will pop up. You must click Allow, otherwise the device cannot be found.

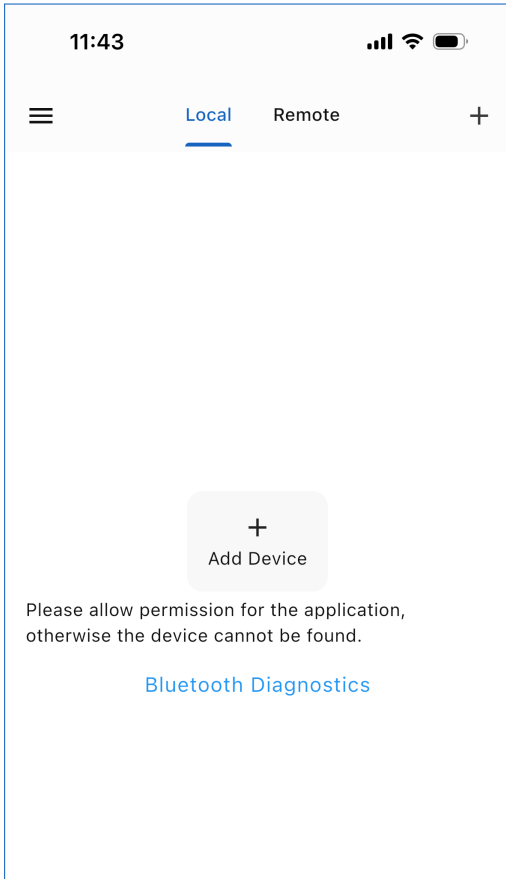

Figure 9: Local Tab

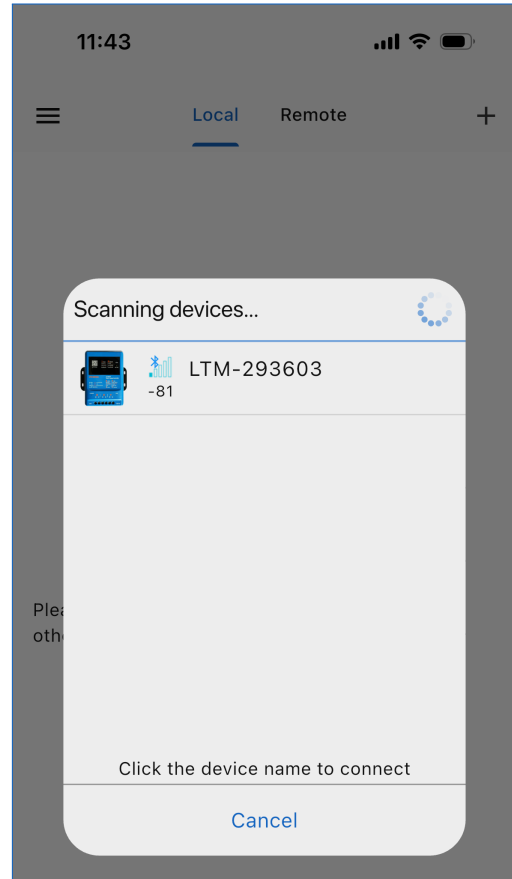

Figure 10: Scan Devices

After finding the device, click the device name to bring up the password input dialog (Figure 11). Enter the initial password "666666" and click Connect. After successful device connection, it will be displayed in the local list (Figure 12).

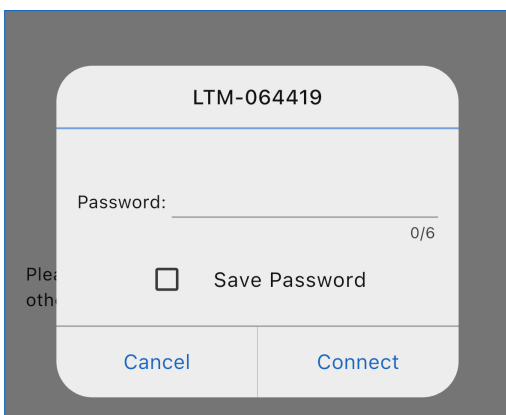

Figure 11: Password Dialog

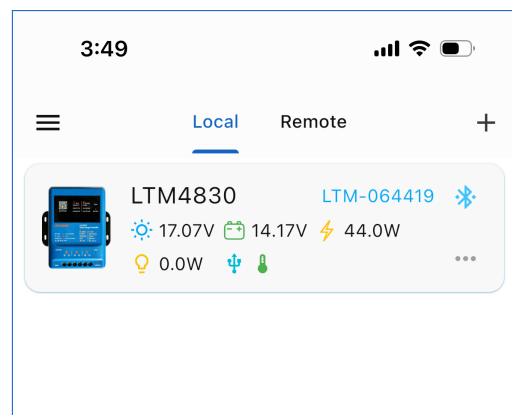

Figure 12: List

7.4 Device IoT Services

After successfully connecting the Bluetooth device, configure the network for the device and bind it to the currently logged-in user account to enable remote monitoring functionality. Click the device name in the local list to enter the device interface (Figure 13). Navigate to the Settings interface through the "Settings" item in the lower right corner, then find "NOI Cloud".

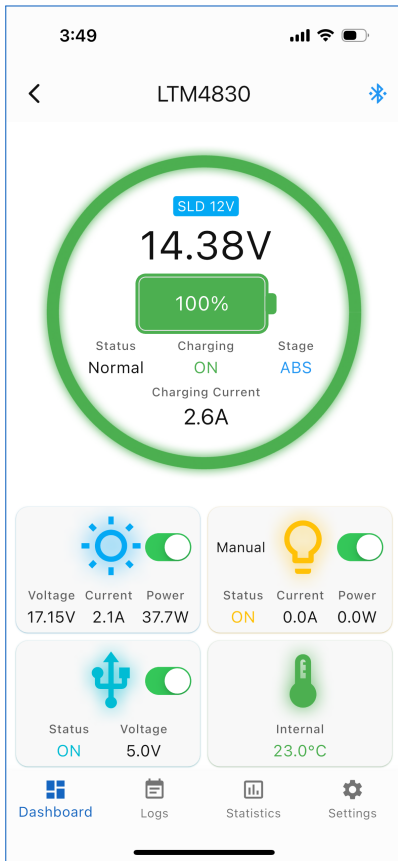

Figure 13: Device Interface

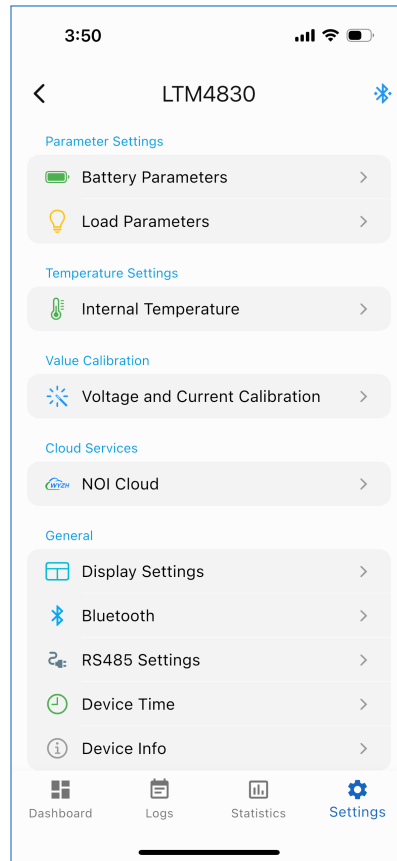

Figure 14: Settings

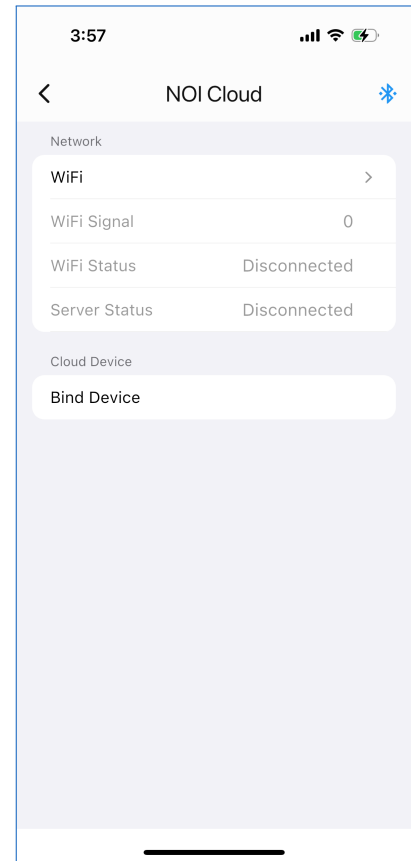

Figure 15: NOI Cloud

In the NOI Cloud interface (Figure 15), click "WiFi" to perform network configuration (Figure 16). Enter WiFi name and password, click the "Continue" button to enter the network configuration process interface (Figure 17). The device needs to connect to WiFi and server, which may take dozens of seconds to several minutes. After successful network configuration, there will be a notification of success (Figure 18).

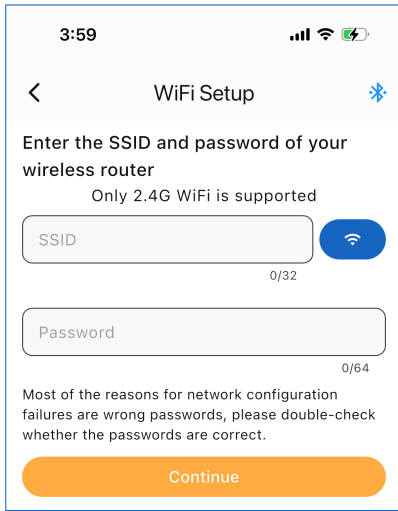

Figure 16: Set WiFi

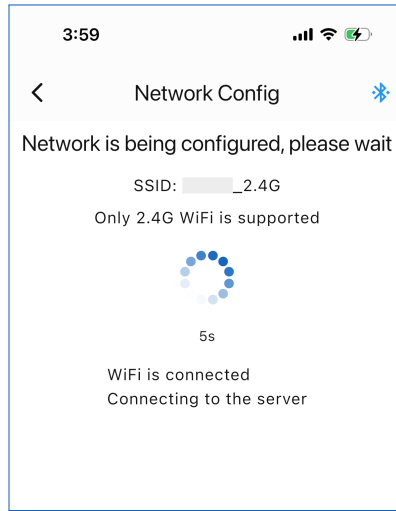

Figure 17: Configuring Network

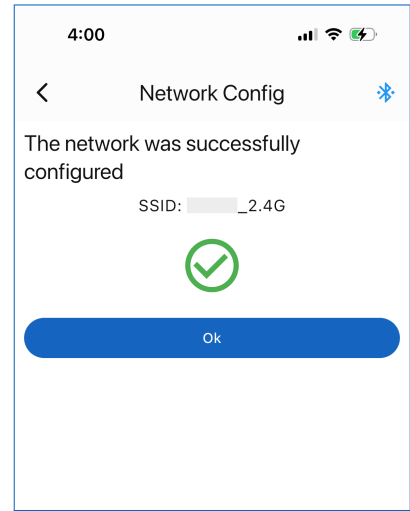

Figure 18: Configuration Successful

Note: Only 2.4G WiFi networks are supported, not 5G WiFi networks. If your wireless router is configured in dual-band mode, please ensure 2.4G and 5G use different SSID names to avoid network configuration failure.

After successful network configuration, binding will be performed automatically, and the NOI Cloud interface will show the device is bound (Figure 19). At this point, exit the device interface and enter the Remote tab (Figure 20). The device will appear in the list.



Figure 19: NOI Cloud

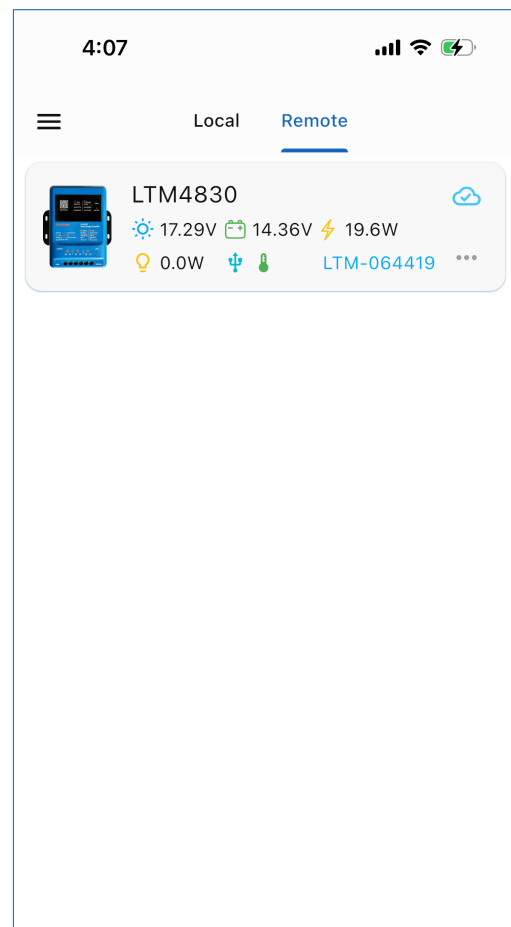

Figure 20: Remote List

In the NOI Cloud interface, you can also unbind the device (Figure 19). Note: After un-

binding, battery configuration information stored on the server will be deleted and cannot be recovered.

Tip: If you don't need remote monitoring functionality, please clear the WiFi configuration.

7.5 Device Status

Click the device name in the list to enter the device interface (Figure 21). On this interface, you can view the device's real-time operating status, including solar panel voltage, current, power, battery voltage, current, charging stage, load voltage, current, and other parameters. Switch the bottom navigation to view device operation logs (Figure 22), data statistics (Figure 23), etc.

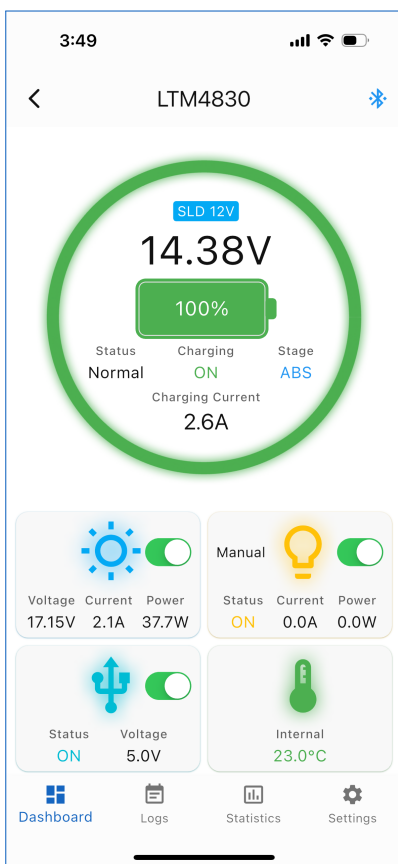

Figure 21: Device Home

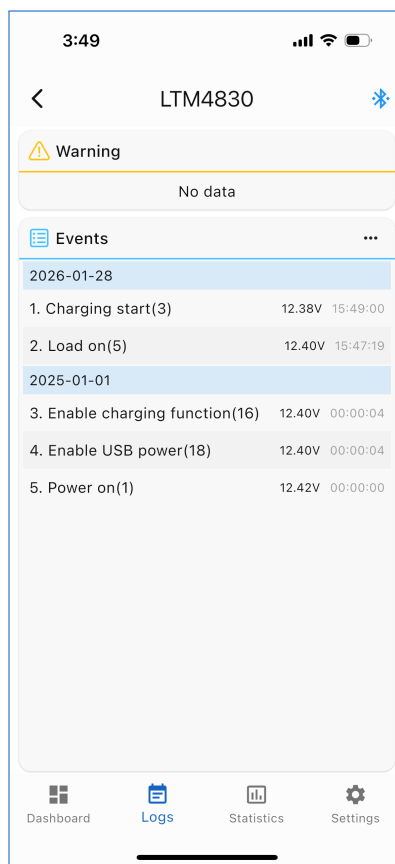

Figure 22: Device Logs

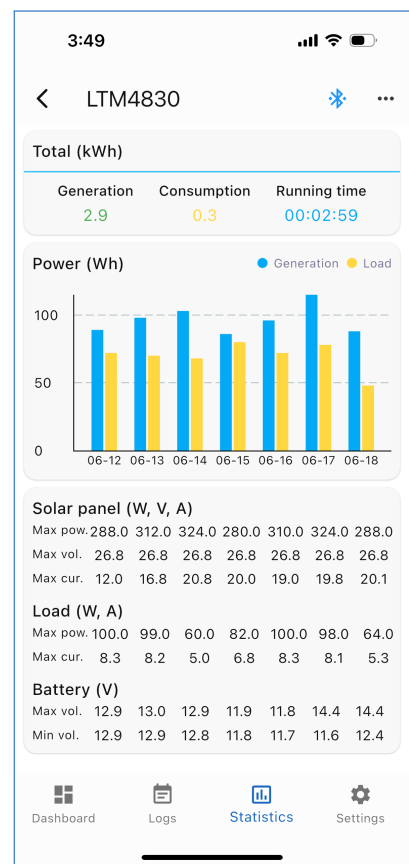

Figure 23: Data Statistics

In the device home interface, the switch on the solar card is used to turn charging on and off, and the switch on the USB card is used to turn USB output on and off. When the load mode is set to manual mode, a quick switch will also appear on the load card to turn load output on and off. If abnormalities occur, corresponding exception notifications will also be displayed on the card. For complete exception alarm information, please check the device log interface (Figure 22).

Tip: In "Display Settings" under Settings, you can configure the display interface of the device home page.

7.6 Battery Parameter Settings

After entering the device interface, click the settings icon in the lower right corner to enter the device settings interface (Figure 24). Click "Battery Parameters" to enter the battery parameter interface (Figure 25). On this interface, you can view the current battery parameters of the controller. To modify battery parameters, click the "Setup Battery" button in the lower right corner to enter the battery type selection interface (Figure 26). Select the appropriate battery type according to the actual battery being used.

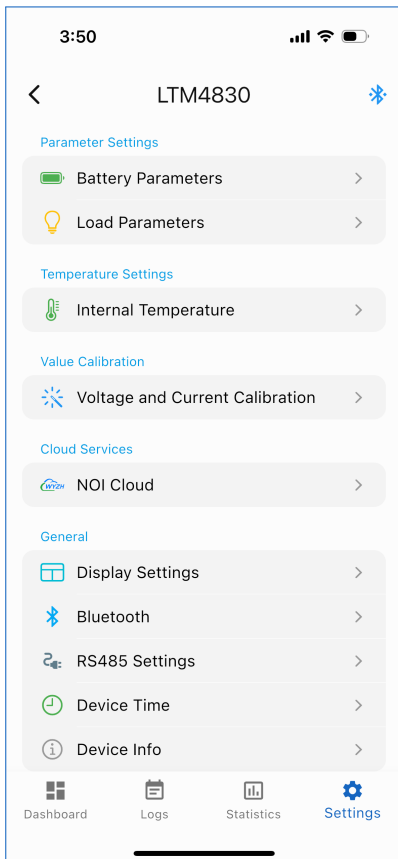

Figure 24: Settings

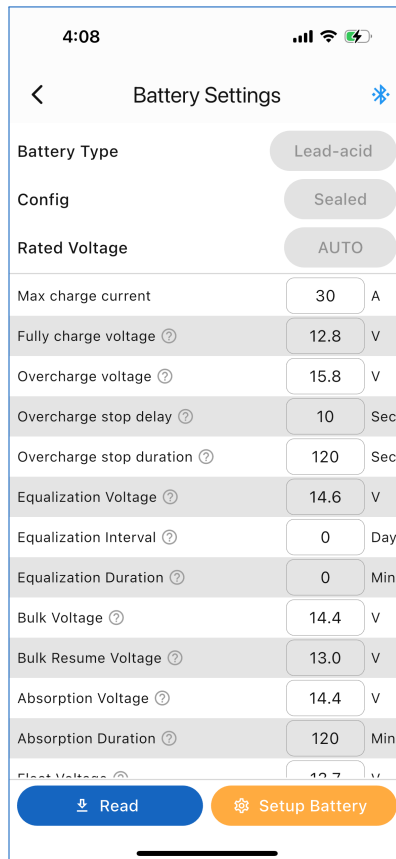

Figure 25: Battery Parameters

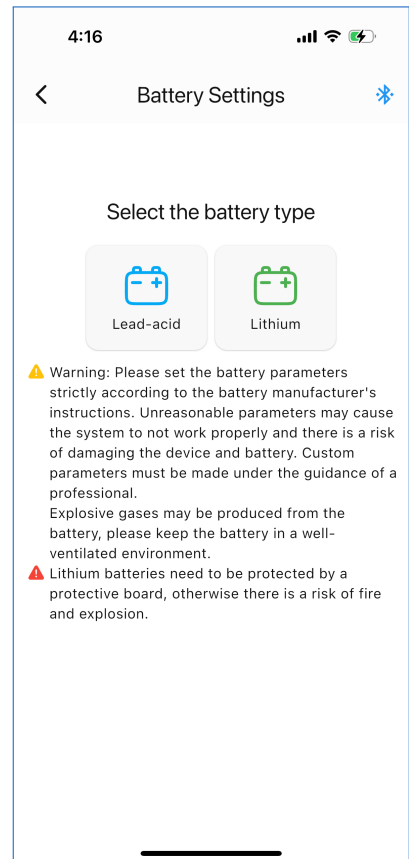

Figure 26: Select Battery Type

7.6.1 Lead-Acid Batteries

Lead-acid battery parameter setting interface (Figure 27). You can select pre-defined three lead-acid battery configurations (Figure 28) and select the appropriate battery voltage type (Figure 29). If "Auto" is selected for voltage type, the controller will automatically detect the battery voltage and calculate the corresponding parameters.

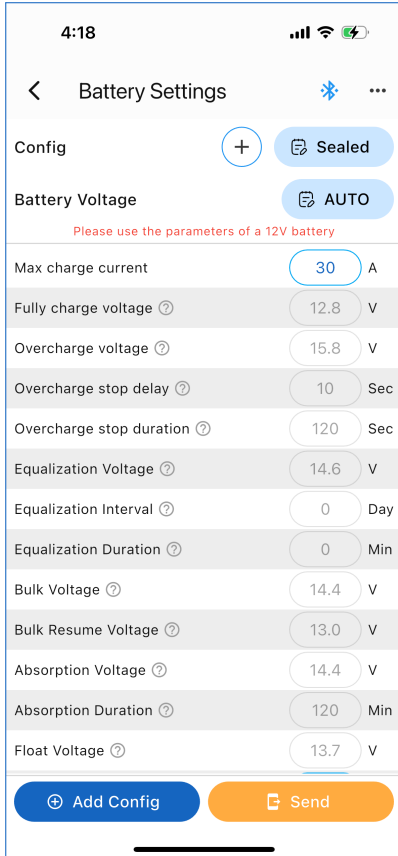

Figure 27: Lead-Acid Parameters

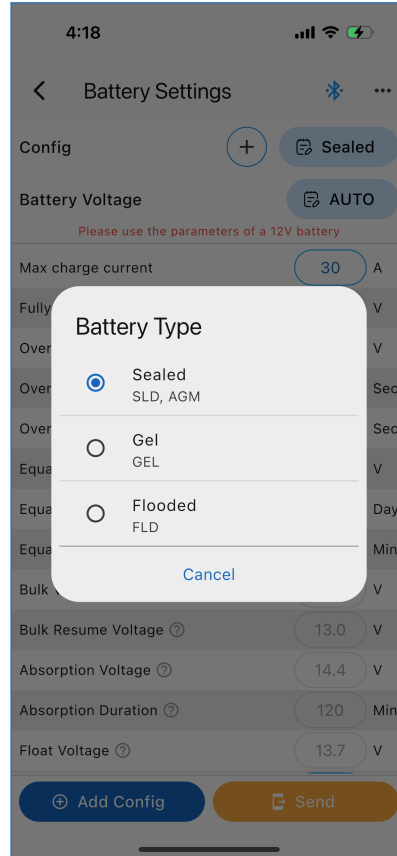

Figure 28: Battery Type

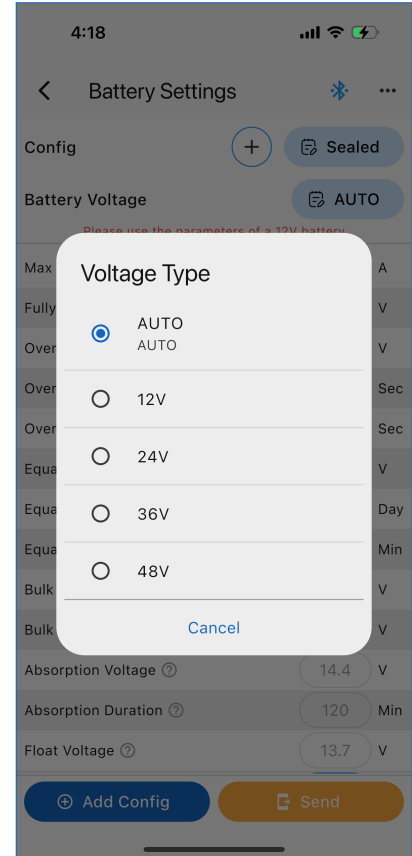

Figure 29: Voltage Type

By default, the three configurations only allow modification of three parameters: "Under-voltage Alarming Voltage", "Low Disconnect Voltage", and "Low Voltage Resume Voltage". To modify other parameters, click the "Add Config" button in the lower left corner to add a new configuration (Figure 30).

Multiple configurations can be added. Added configurations allow modification of all parameters (Figure 27).

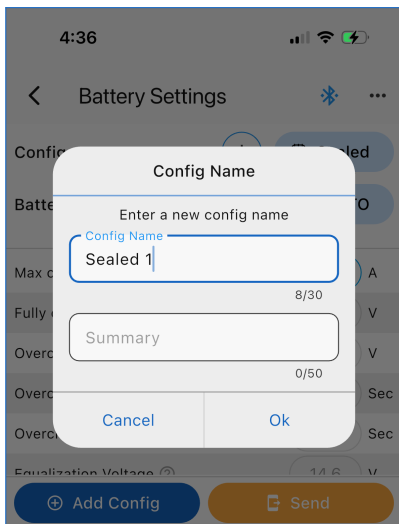

Figure 30: Add Config

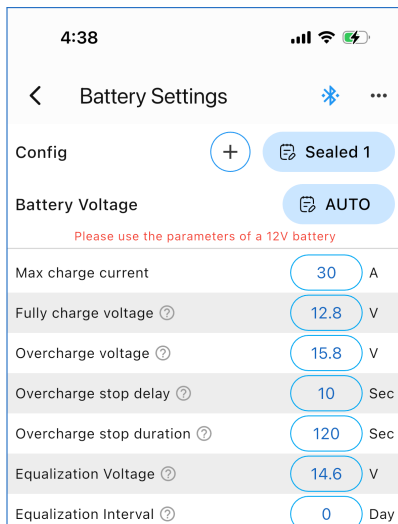

Figure 31: Lead-Acid Battery Parameters

Click the question mark after parameters to view help information for that parameter.

Note: Please strictly fill in the corresponding parameter values according to the battery manual. Incorrect parameters may cause battery damage.

7.6.2 Lithium Batteries

Lithium battery parameter setting interface (Figure 32). You can directly adjust parameter values or use the battery parameter assistant (Figure 33) to input battery series count to generate parameters automatically.

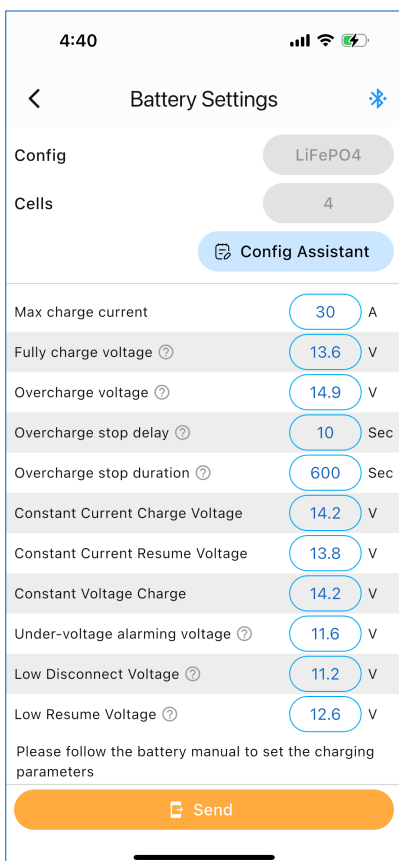

Figure 32: Lithium Battery Parameters

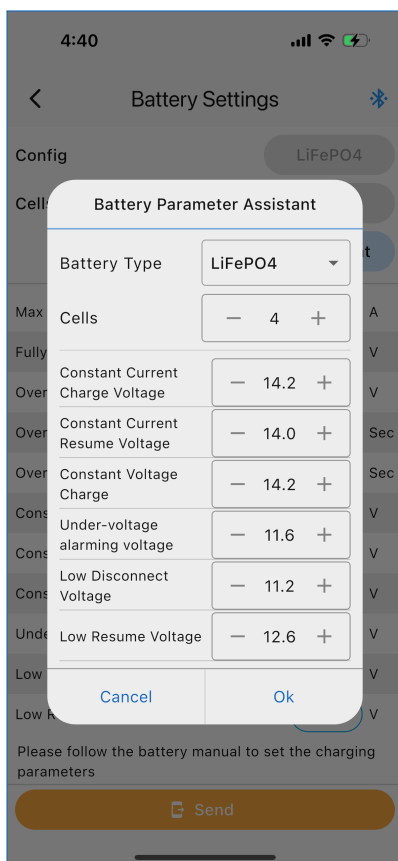

Figure 33: Battery Parameter Assistant

Automatically generated parameters are our preset values. Users can adjust them according to the actual situation of the battery.

Note: Please strictly fill in the corresponding parameter values according to the battery manual. Incorrect parameters may cause battery damage.

7.7 Load Parameter Settings

In the device settings interface, select "Load Mode" to enter the load mode setting interface (Figure 34). On this interface, you can select different load control modes such as Always On, Manual, Light Control, etc., and set them according to actual needs.

Warning: Turning off short circuit protection may damage the controller if the load experiences a short circuit. Please operate with caution.

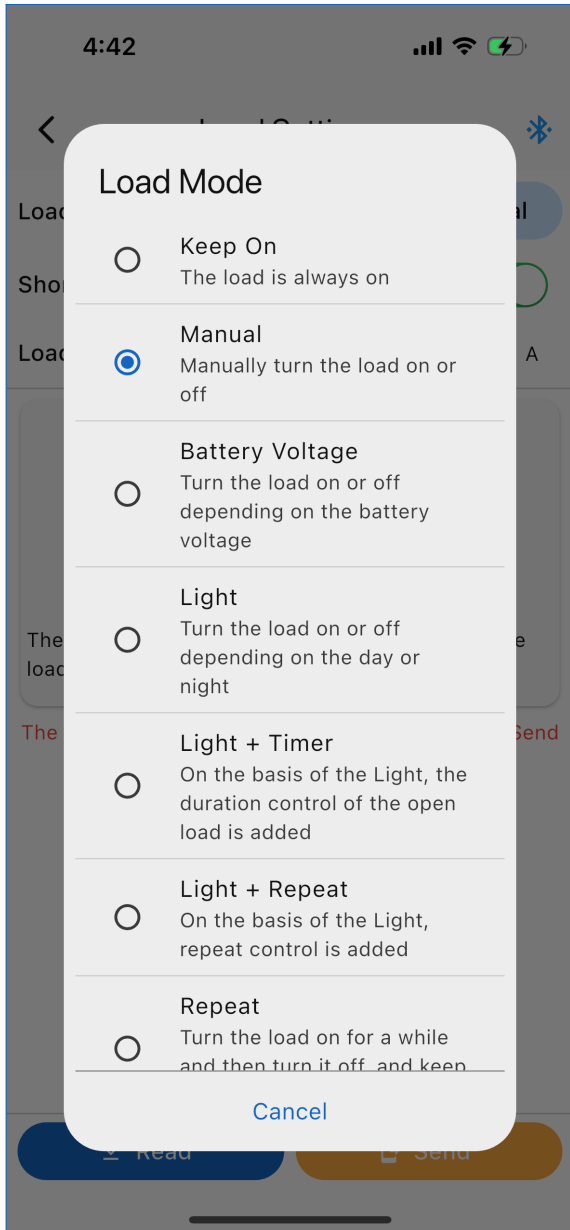

Figure 34: Load Mode

In the load mode setting interface, there are detailed descriptions of parameters. Please set according to the prompts in the APP.

7.8 Time Setting

The controller's time is very important for timed load control modes. If the time is inaccurate, the recorded time in device logs will also be incorrect. After device power loss,

Each load mode has its corresponding setting interface. Users can adjust parameters according to their needs.

Always On: Load always on.

Manual: User can manually control load on/off.

Battery Controlled: Open/close load based on battery voltage.

Light Control: Open/close load based on light intensity.

Light Timer: Open/close load based on light intensity, with set load duration time.

Light Repeat: Open/close load based on light intensity, with set load cycle control.

Repeat: Set load to turn on/off in cycles.

Segments: Open/close load based on time segments.

Output Reverse: In light control mode, the load open/close logic is reversed. This can achieve the function of opening load during day and closing at night.

the internal time will be lost, and correct time needs to be synchronized from the phone or server. There are two ways to synchronize time: local Bluetooth synchronization and remote WiFi synchronization.

Local Bluetooth Synchronization

Select "Device Time" in device settings to enter the device time setting interface (Figure 35). Click the "Sync Time" button to sync the phone's current time to the controller. Turn on the "Auto Sync Time When Connected" option, and each time you connect to the device via Bluetooth, the time will be automatically synchronized.

Remote WiFi Synchronization

In the "NOI Cloud" interface (Figure 19), click "Device Time" to enter the device time interface (Figure 36). Remote time synchronization requires setting the timezone where the device is located. If the device timezone setting is incorrect, it will result in time errors.

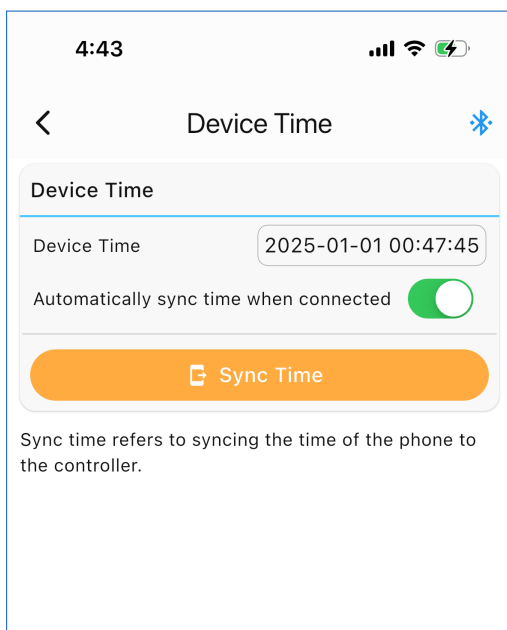

Figure 35: Local Time Setting

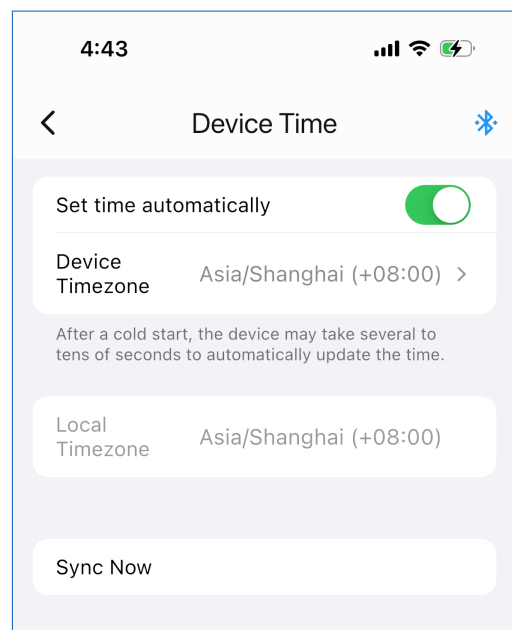

Figure 36: Remote Time Setting

Note: If the device time is incorrect, the Segments mode of the load will not work as expected. If using Segments mode, please ensure the device time is accurate.

7.9 Bluetooth Settings

In the device settings interface, select "Bluetooth" to enter the Bluetooth settings interface (Figure 37). You can modify the Bluetooth name (Figure 38) and Bluetooth password (Figure 39).

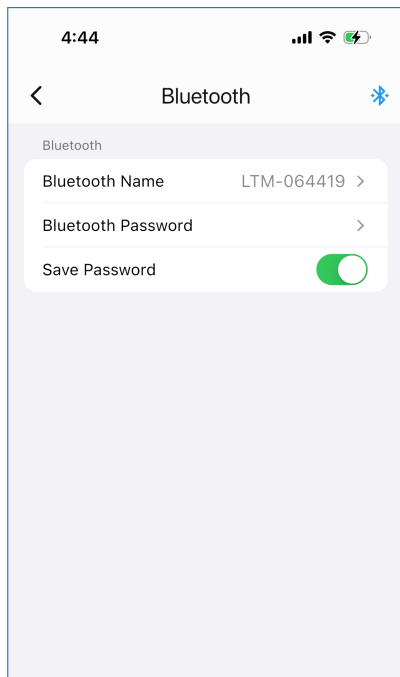

Figure 37: Bluetooth Settings

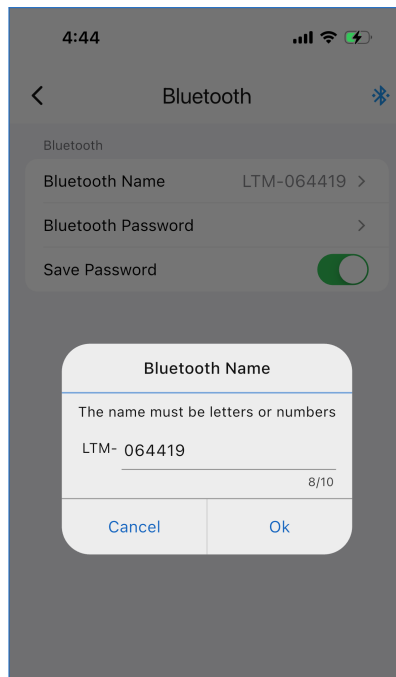

Figure 38: Modify Bluetooth Name

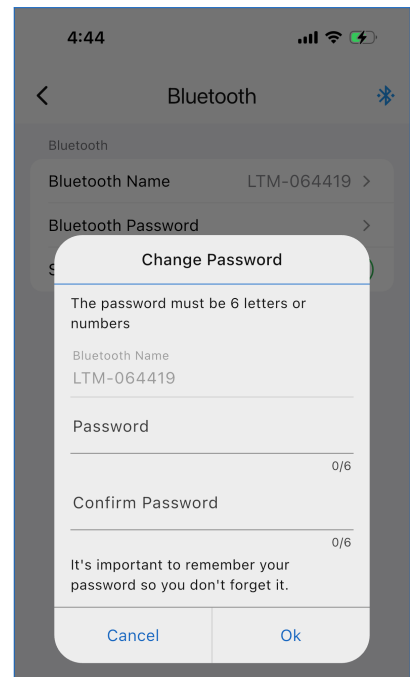

Figure 39: Modify Bluetooth Password

Tip: After modifying the Bluetooth name, the new name will be displayed when searching for the device next time. After modifying the Bluetooth password, remember the new password.

7.10 Device Information and Firmware Upgrade

In the device settings interface, select "Device Information" to enter the device information interface (Figure 40). On this interface, you can view device information such as model, serial number, firmware version, etc. At the same time, you can check if new firmware versions are available and perform firmware upgrade operations.

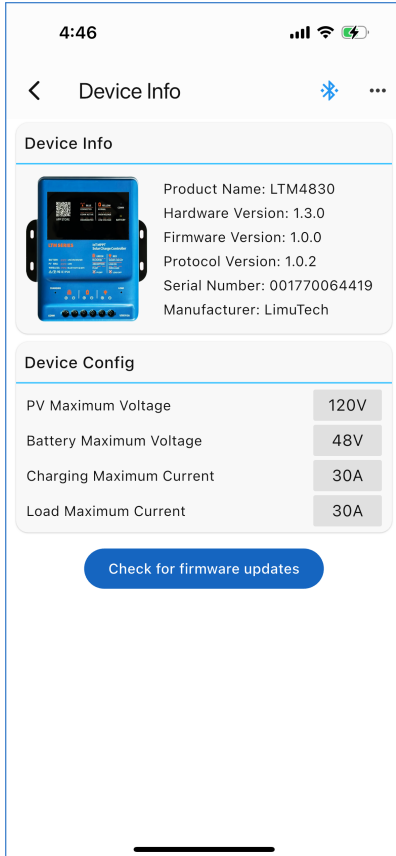

Figure 40: Device Information

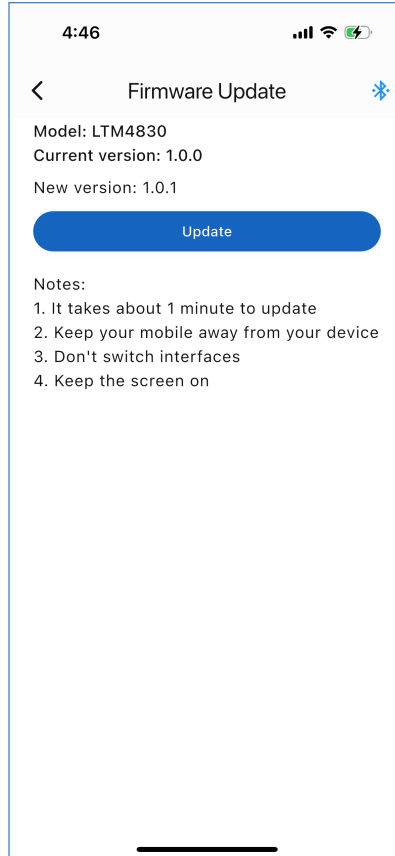

Figure 41: Check Firmware Updates

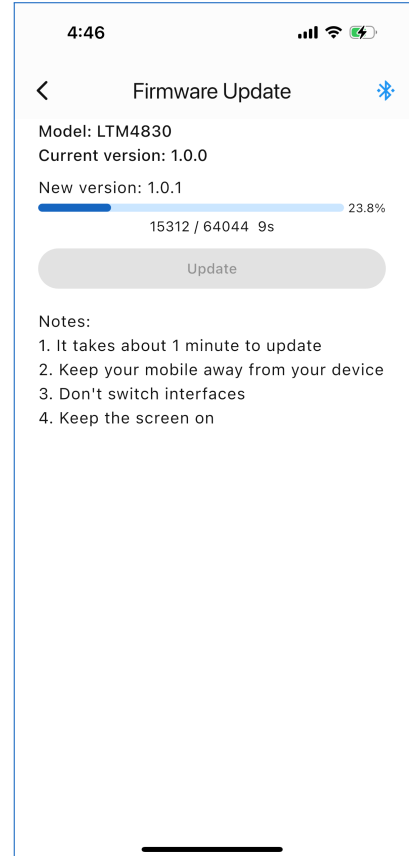

Figure 42: Firmware Upgrade

For Bluetooth upgrades, keep the distance between phone and device within 3 meters, don't exit the upgrade page, and prohibit entering screen sleep state.

For remote upgrades, a stable network environment is required. Please ensure both phone and controller are in stable WiFi condition. If upgrade fails, don't exit the upgrade interface; click the "Update" button again to retry. If the device cannot be remotely connected after upgrade failure, please go on-site to restart the device and perform the upgrade locally via Bluetooth.

*The APP will receive version updates and upgrades. The interface and functions may change. Please refer to the actual product.

Declaration: The content of this user manual and the final interpretation rights of this product belong to the company. Any updates to this manual will not be separately notified. Please refer to the latest materials released by the company.

